

**Residential Turn Around For No More Than 2 Dwelling Units When A Dead End Fire Access Exceeds 150 Feet**

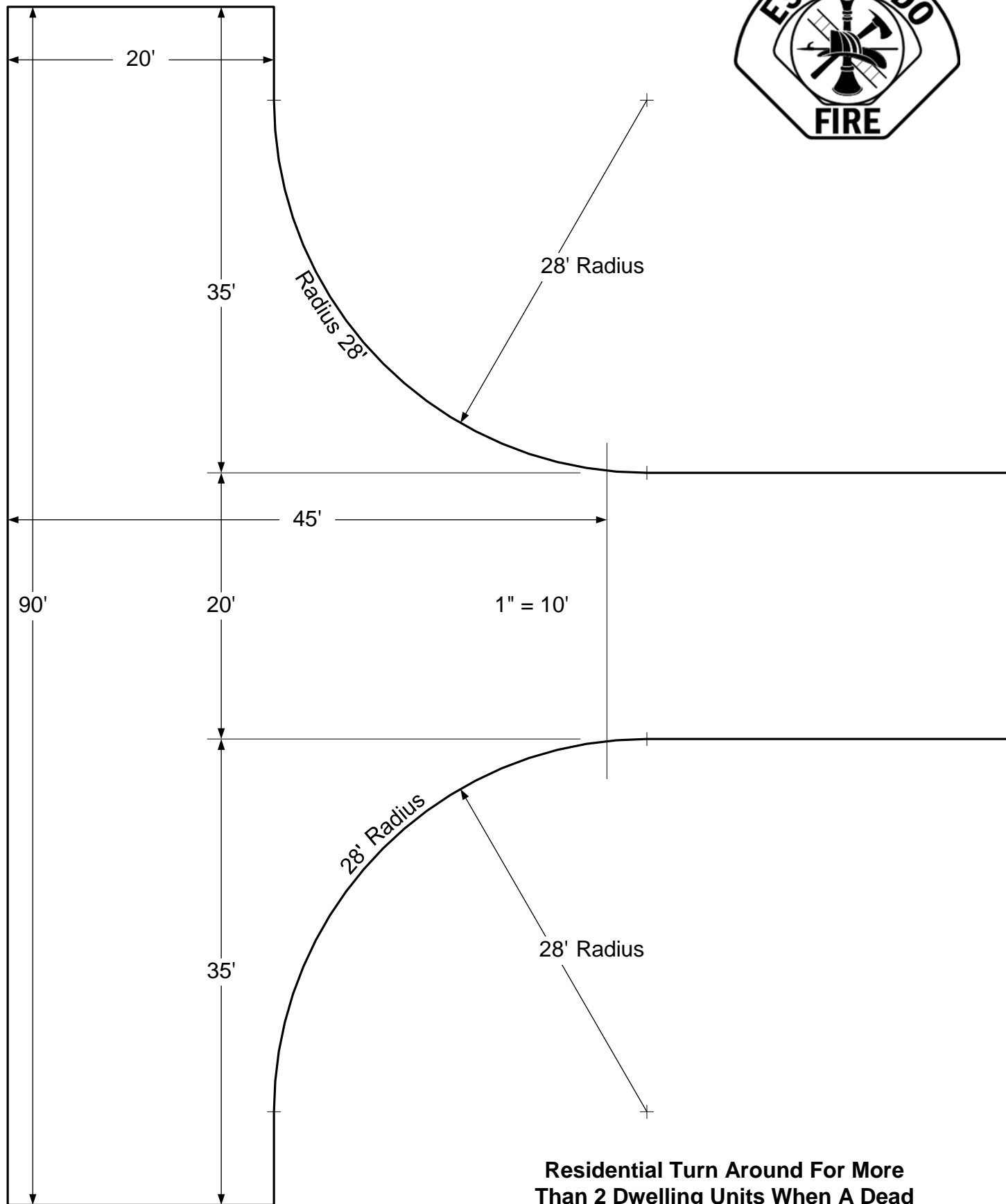

**Residential Turn Around For More Than 2 Dwelling Units When A Dead End Fire Access Exceeds 150 Feet**

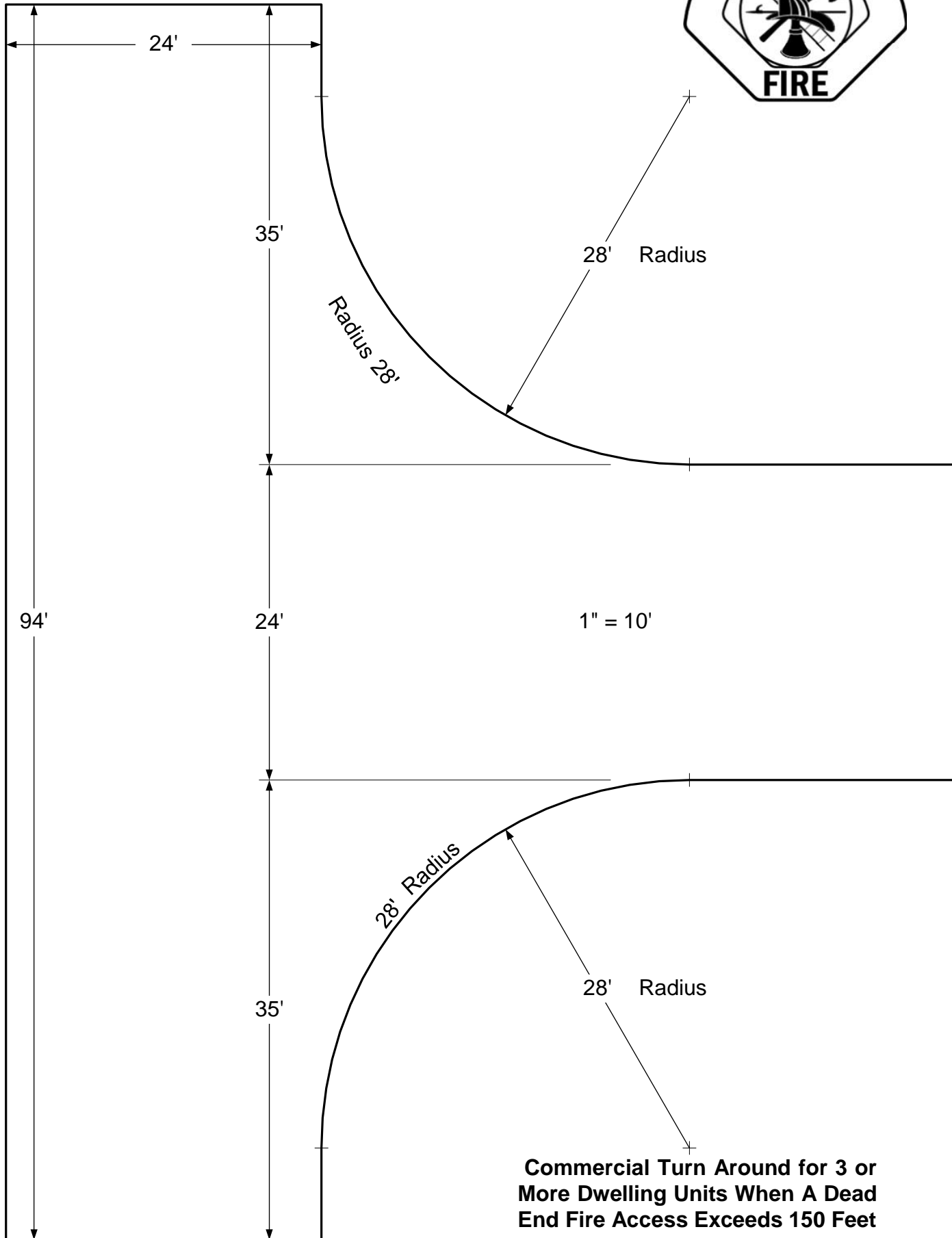

**Commercial Turn Around for 3 or More Dwelling Units When A Dead End Fire Access Exceeds 150 Feet**

Scale: 1" = 10'

Revised: 09-3-2015

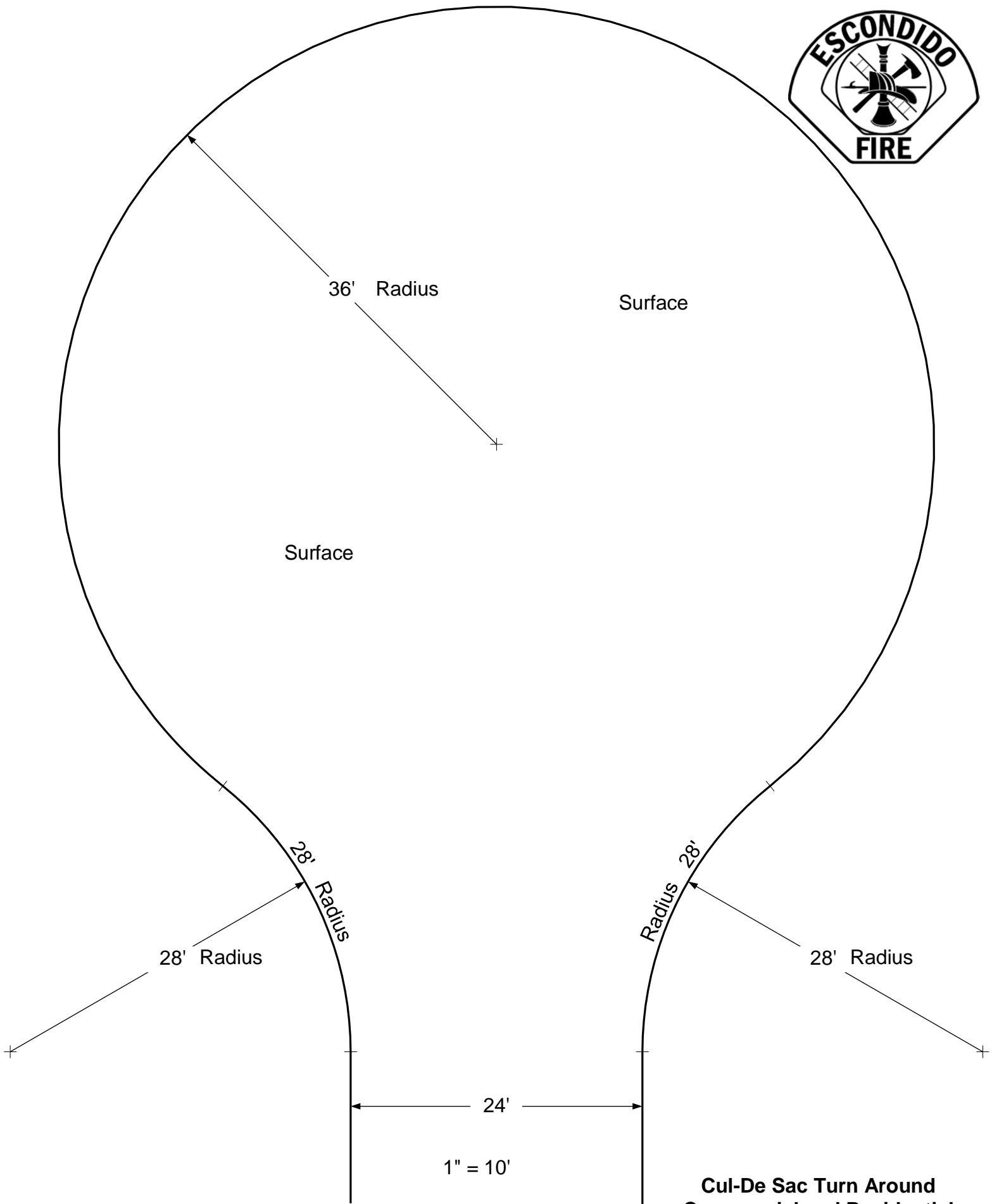

NOTE: All turn arounds list minimum dimensions. If parking is required, eight feet must be added to each side of the fire access road and turn around where parking is specified

**Cul-De Sac Turn Around  
Commercial and Residential  
(More Than 2 Dwelling Units)**

Scale: 1" = 10'

Revised: 09-3-2015

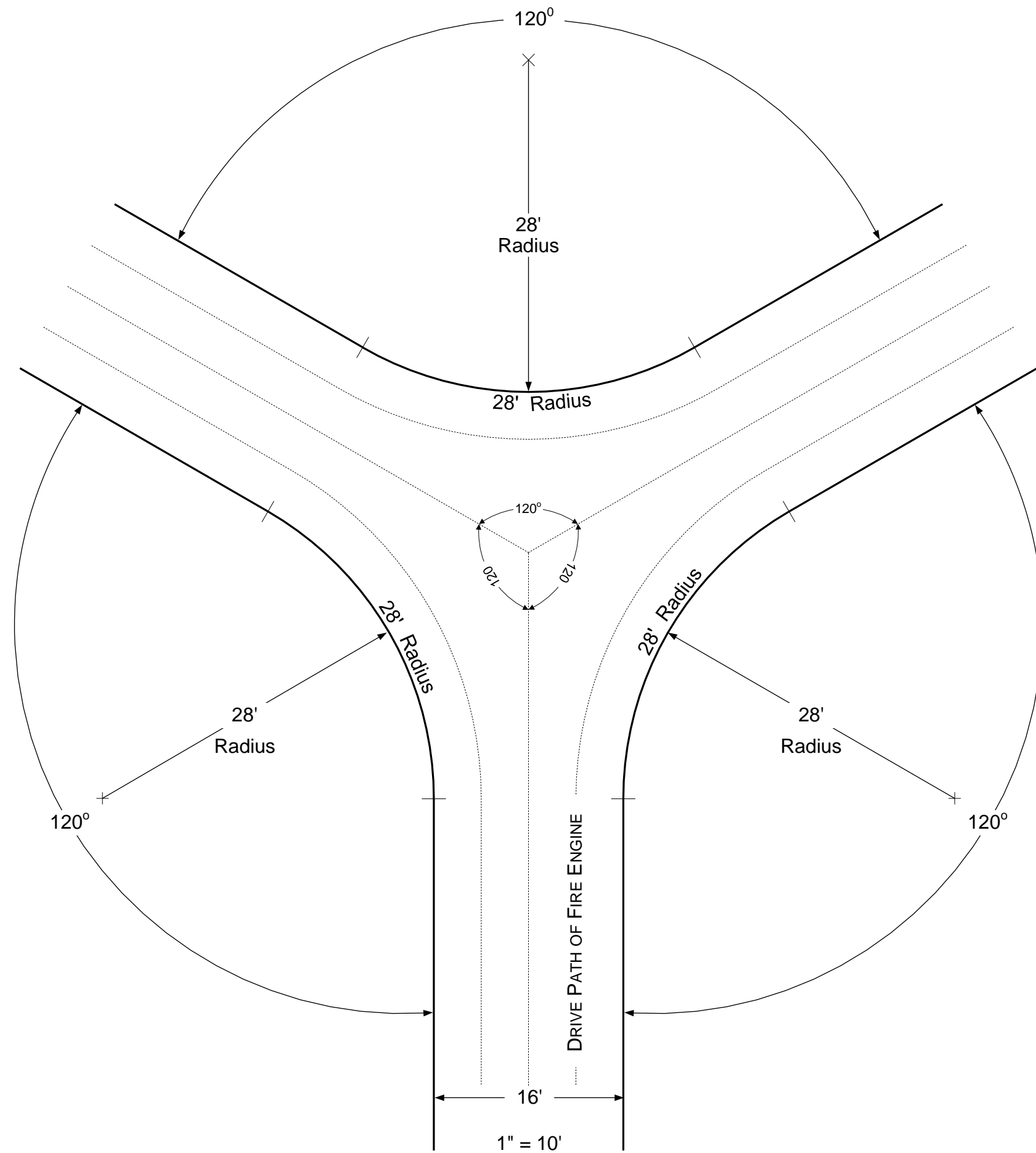

**Residential  
Hammerhead Alternative**

Scale: 1" = 10' Revised: 09-3-2015

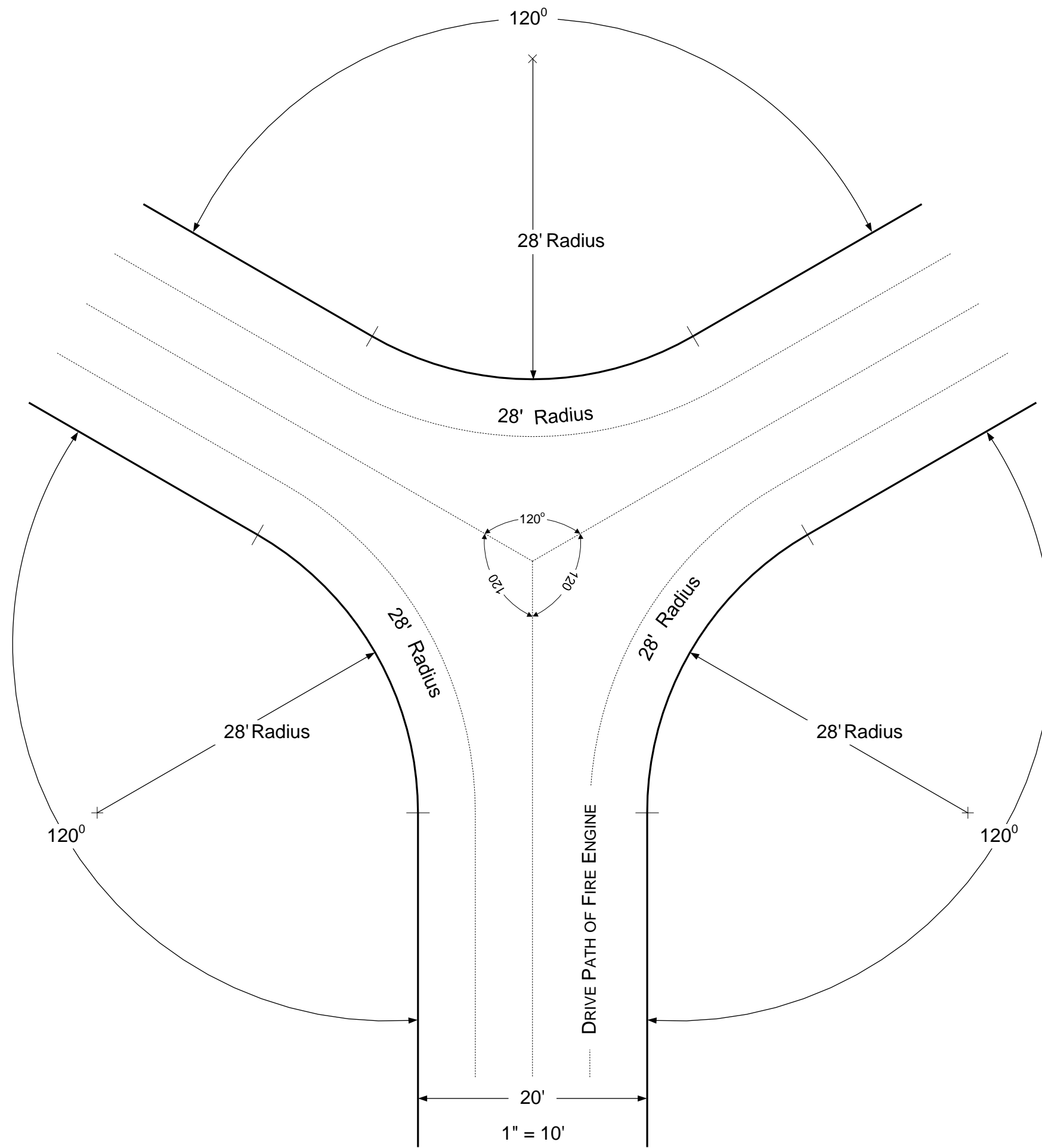

**Residential  
Hammerhead Alternative**

Scale: 1" = 10' Revised: 09-3-2015



PROPERTY LINE

PROPERTY LINE

### 24' Wide Standard Roadway

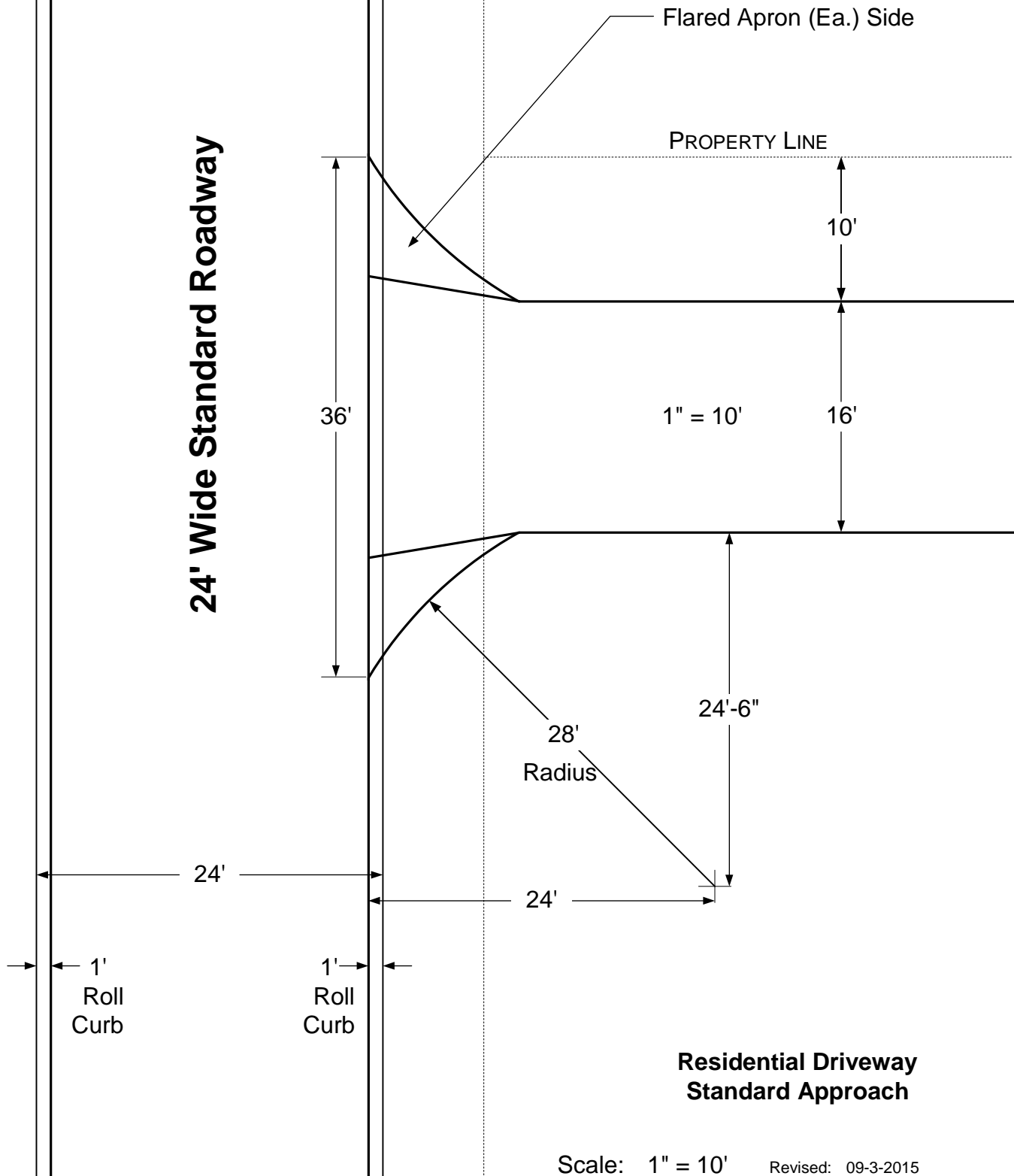

Flared Apron (Ea.) Side

PROPERTY LINE

10'

36'

1" = 10'

16'

24'-6"

28'  
Radius

24'

24'

1'  
Roll  
Curb

1'  
Roll  
Curb

**Residential Driveway  
Standard Approach**

Scale: 1" = 10'

Revised: 09-3-2015

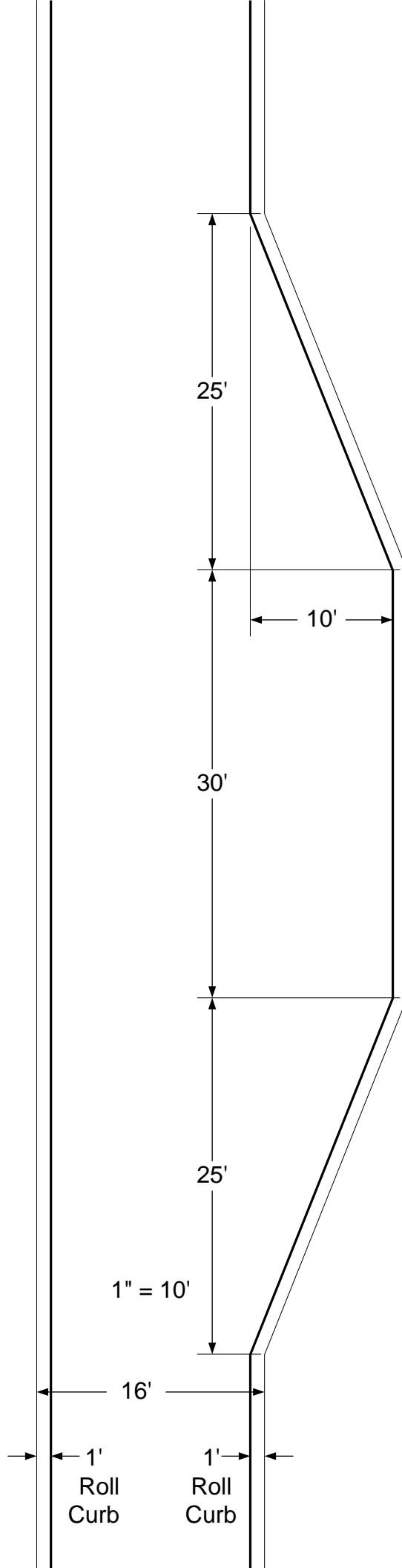

**Turn Out**

Scale: 1" = 10'

Revised: 09-3-2015





**Residential Turn Around For No More Than 2 Dwelling Units When A Dead End Fire Access Exceeds 150 Feet**

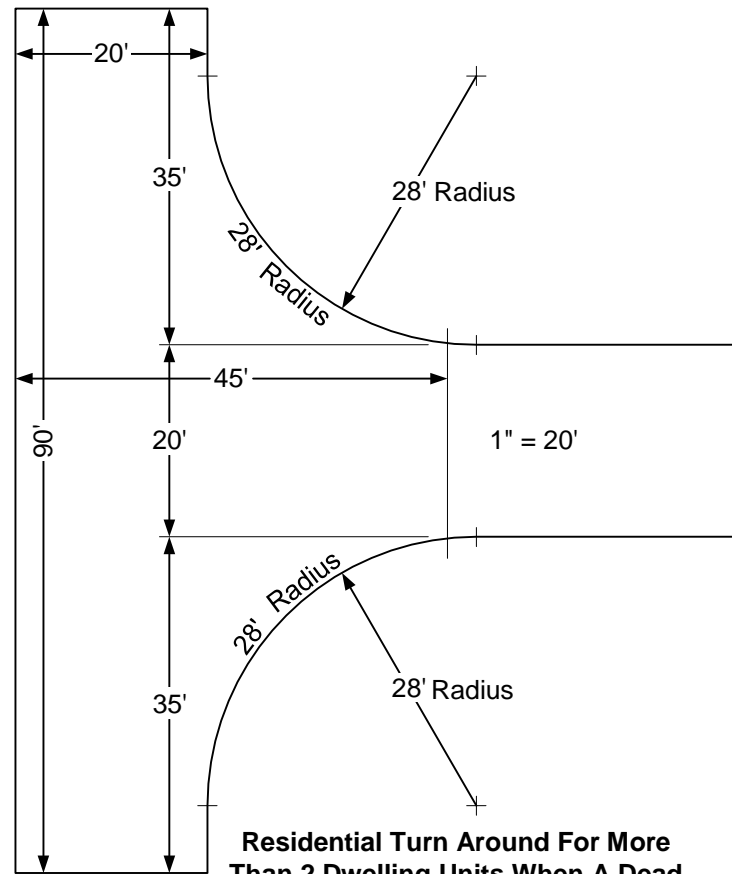
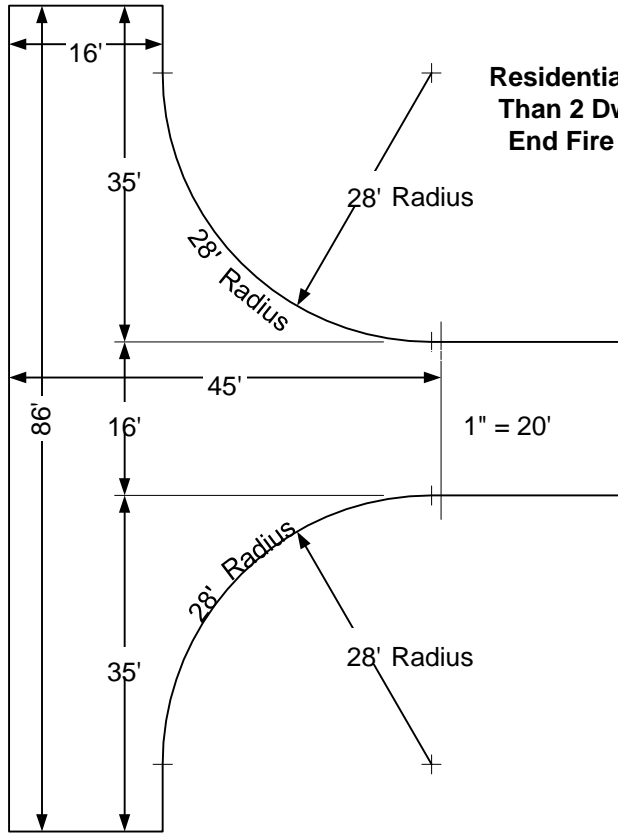

**Residential Turn Around For More Than 2 Dwelling Units When A Dead End Fire Access Exceeds 150 Feet**

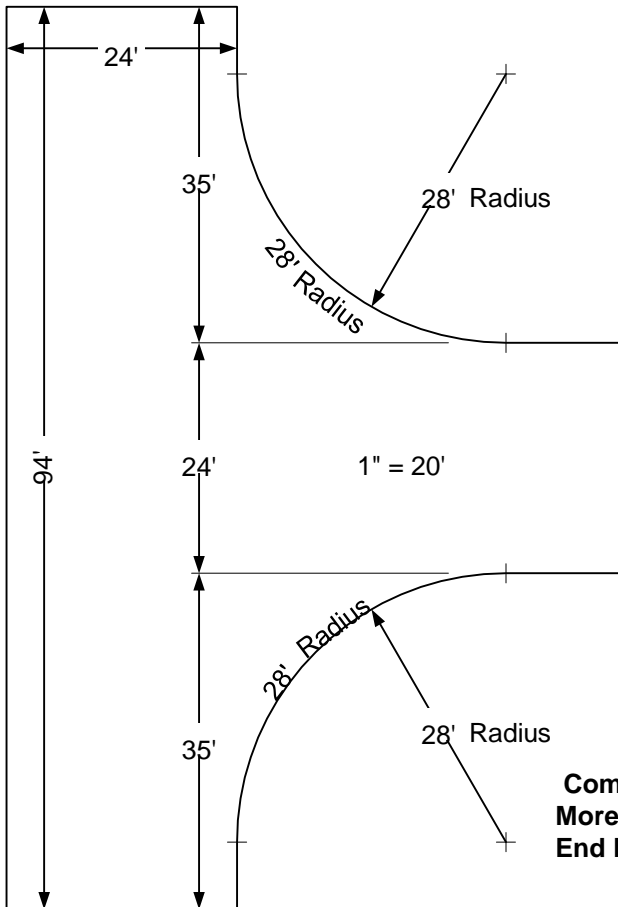

**Commercial Turn Around for 3 or More Dwelling Units When A Dead End Fire Access Exceeds 150 Feet**

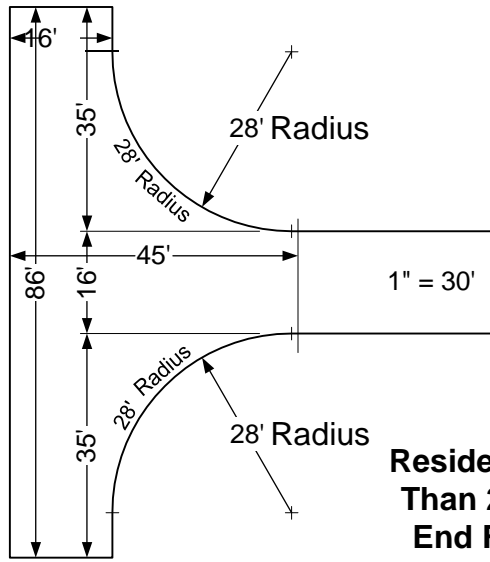

**Residential Turn Around For No More Than 2 Dwelling Units When A Dead End Fire Access Exceeds 150 Feet**

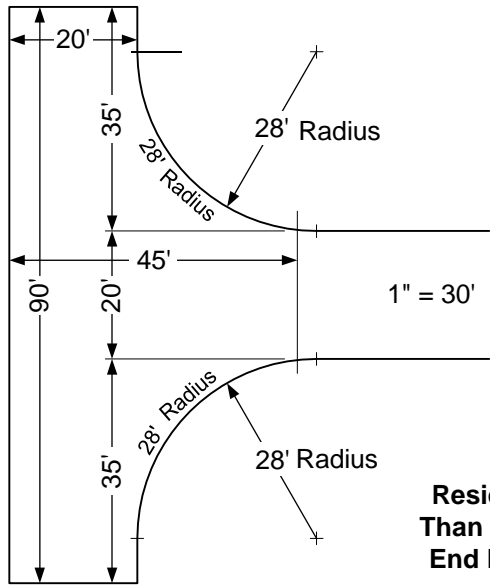

**Residential Turn Around For More Than 2 Dwelling Units When A Dead End Fire Access Exceeds 150 Feet**

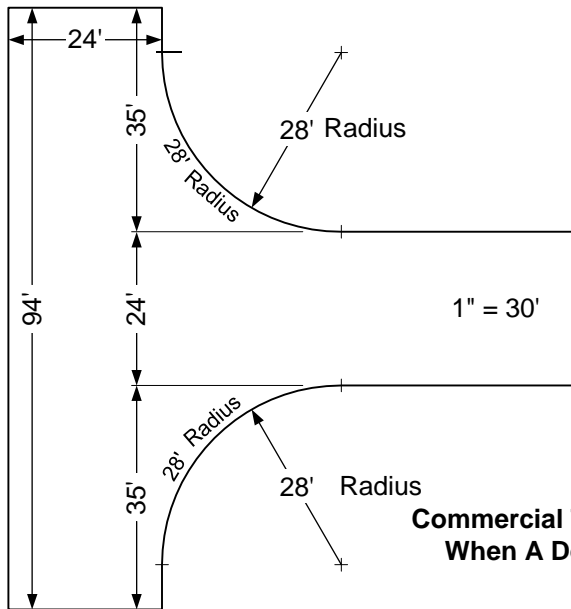

**Commercial Turn Around for 3 or More Dwelling Units When A Dead End Fire Access Exceeds 150 Feet**

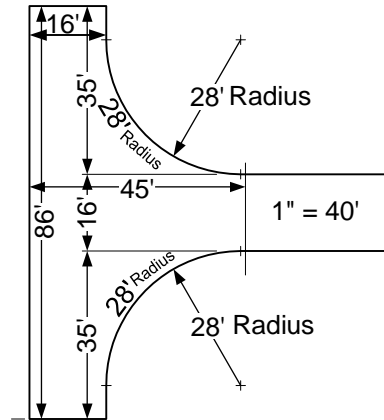

**Residential Turn Around For No More Than 2 Dwelling Units When A Dead End Fire Access Exceeds 150 Feet**

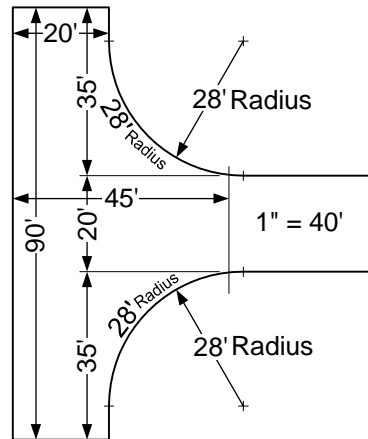

**Residential Turn Around For More Than 2 Dwelling Units When A Dead End Fire Access Exceeds 150 Feet**

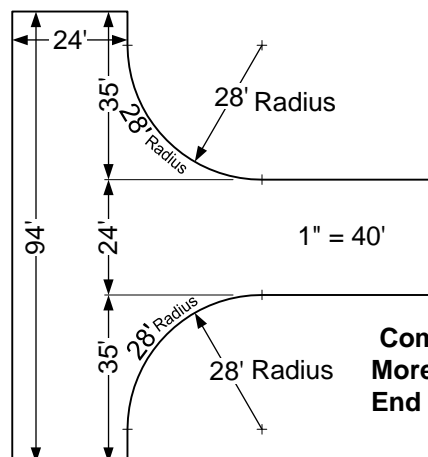

**Commercial Turn Around for 3 or More Dwelling Units When A Dead End Fire Access Exceeds 150 Feet**

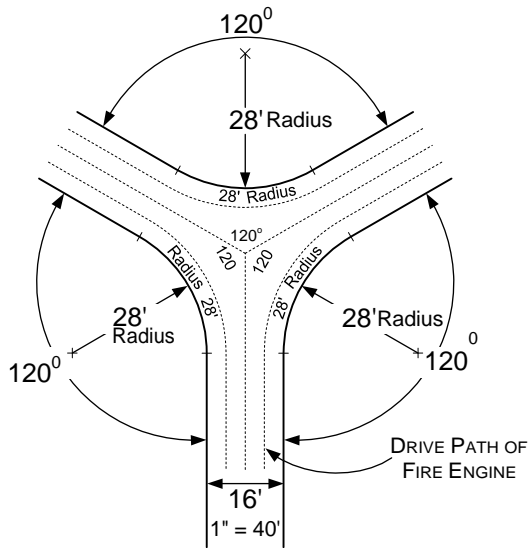

**Residential  
Hammerhead Alternative**

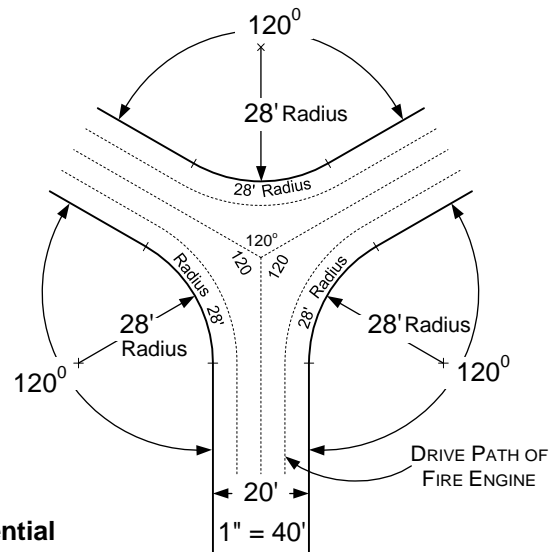

**Cul-De Sac Turn Around  
Commercial and Residential  
(More Than 2 Dwelling Units)**

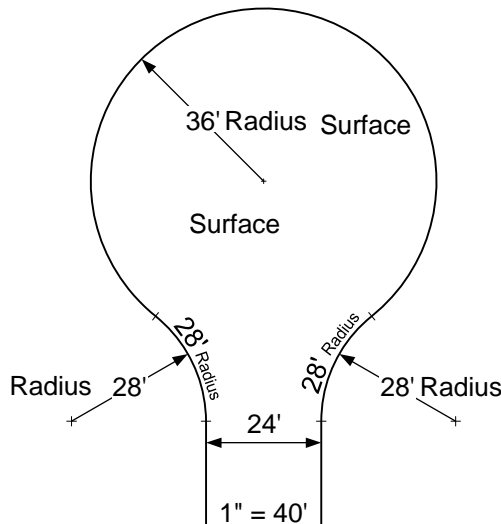

NOTE: All turn arounds list minimum dimensions. If parking is required, eight feet must be added to each side of the fire access road and turn around where parking is specified

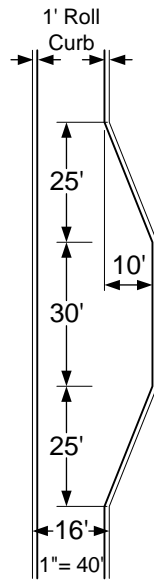

**Turn Out**

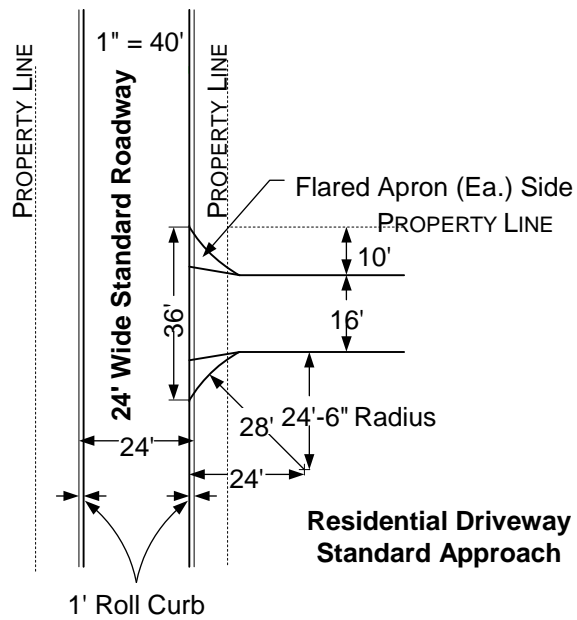

**Residential Driveway  
Standard Approach**

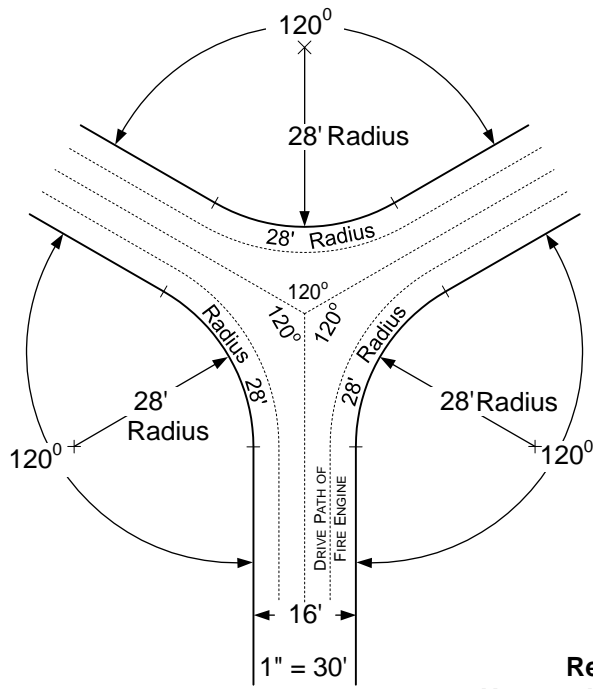

**Residential  
Hammerhead Alternative**

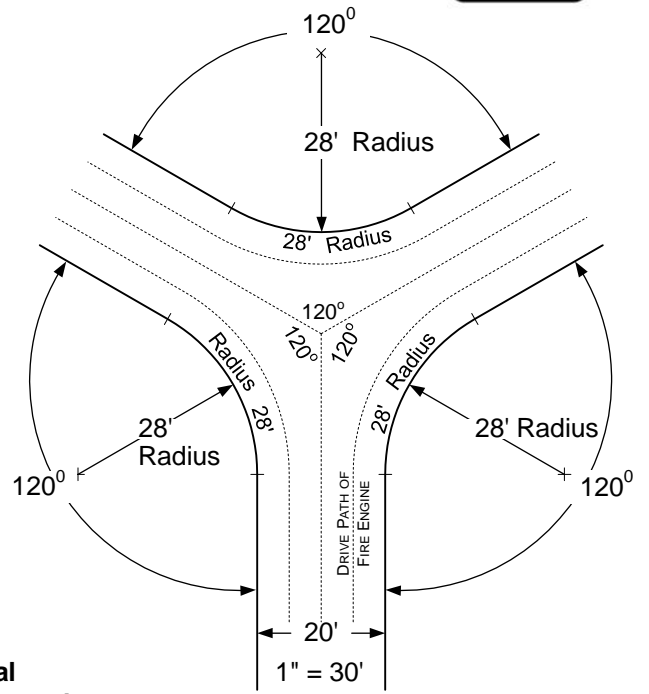

**Cul-De Sac Turn Around  
Commercial and Residential  
(More Than 2 Dwelling Units)**

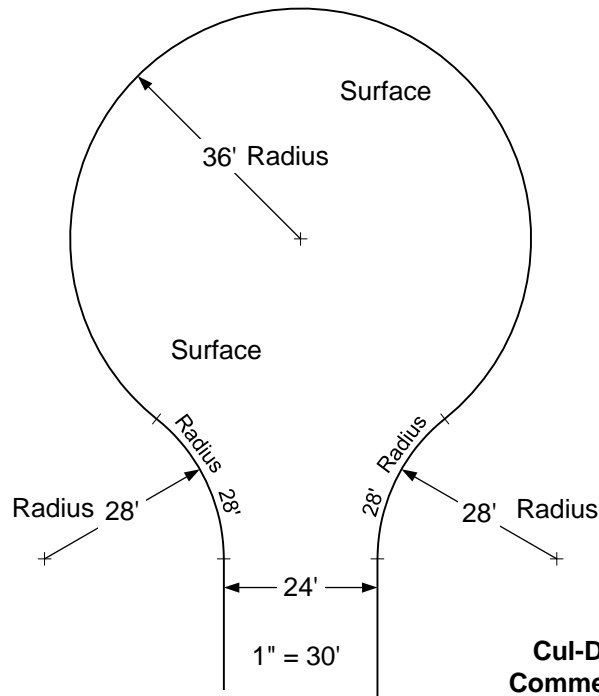

NOTE: All turn arounds list minimum dimensions. If parking is required, eight feet must be added to each side of the fire access road and turn around where parking is specified

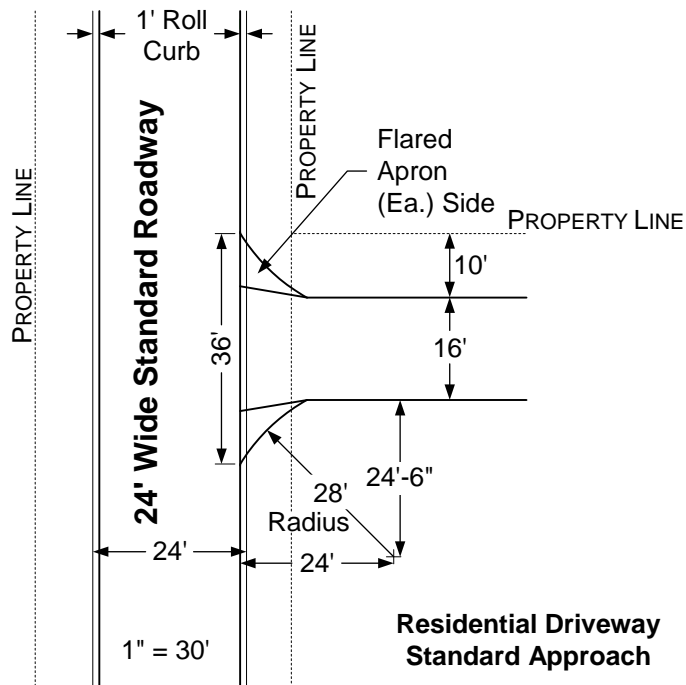
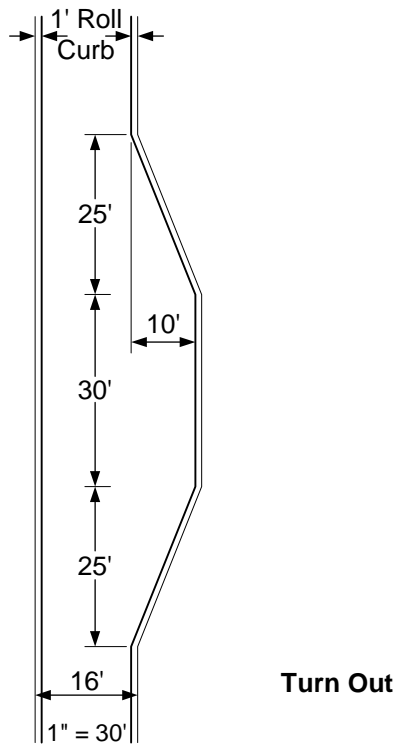

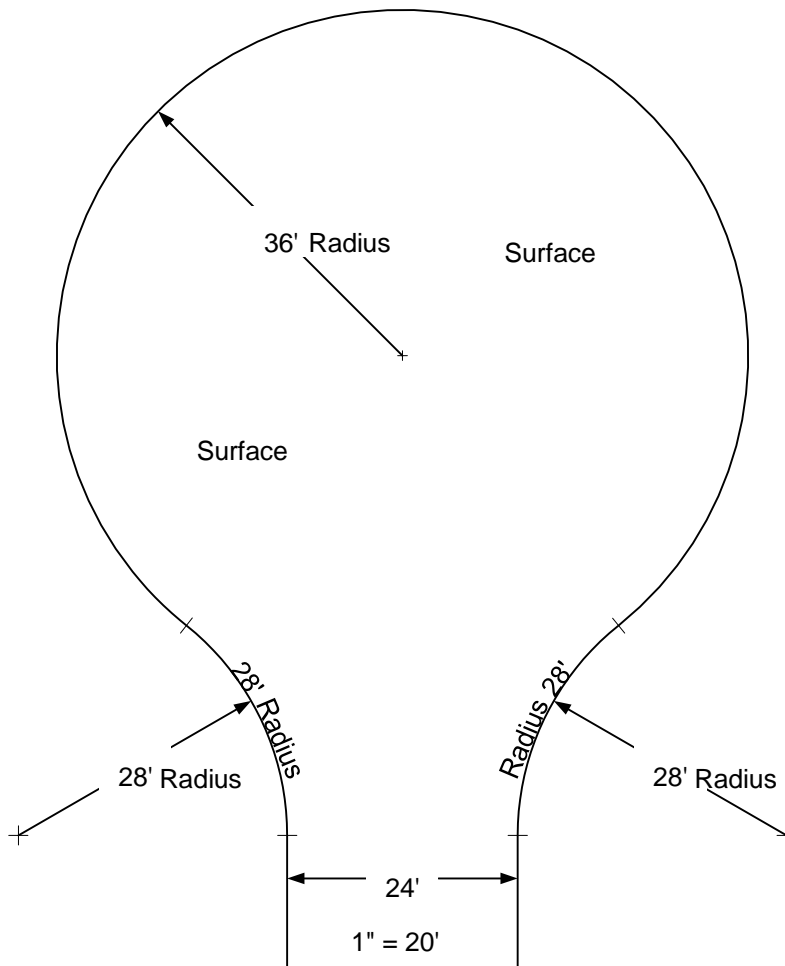

NOTE: All turn arounds list minimum dimensions. If parking is required, eight feet must be added to each side of the fire access road and turn around where parking is specified

**Cul-De Sac Turn Around  
Commercial and Residential  
(More Than 2 Dwelling Units)**



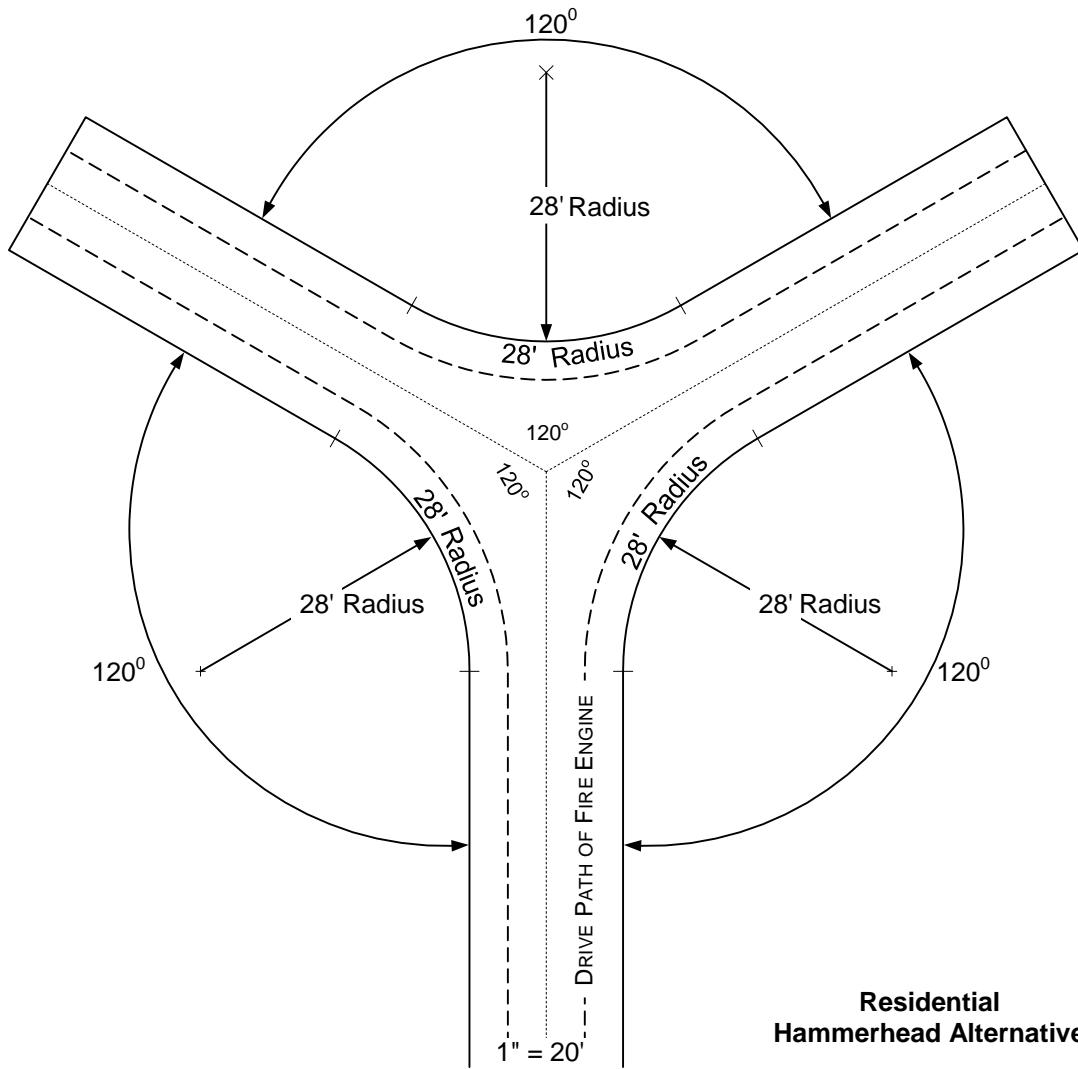

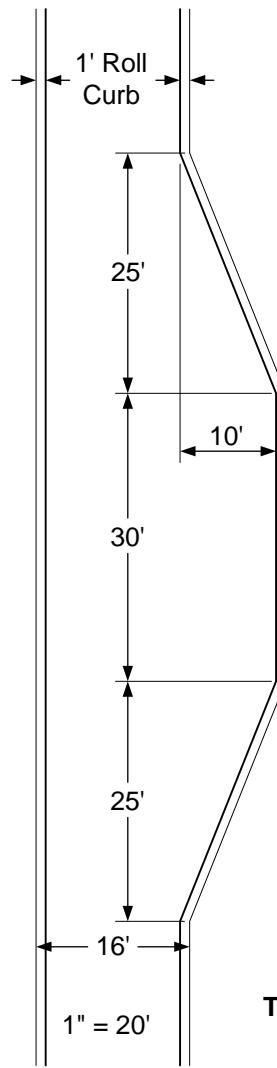

Turn Out

